

X-FSC/X-FRZ

Position Limit Switch



Cross position limit switches designed for controlling the movement of overhead travelling cranes, hoists and complex machine tools. Heads with different types of rods and movement for specific applications.



FEATURES

- 2 fixing holes.
- Positive opening NC contacts for safety functions.
- Mechanical life of switches: 1 million operations.
- Operation frequency: 3600 operations/hour max.
- IP protection degree: X-FSC and X-FRZ are classified IP65 with specific cable clamp M20.
- Extreme temperature resistance: -13°F to +158°F (-25°C to +70°C).
- Enclosure and head in thermoplastic material.
- All materials and components used are wear resistant and guarantee protection of the unit against water and dust.

OPTIONS

- 2 snap action switches with 1NO+1NC change-over contacts or slow action switches with 1NC contact.
- X-FCS features cross rods in 3 or 4 maintained positions or T rods in 3 maintained position, movement every 90°.
- X-FRZ has a single rod or a rod with roller with 65° movements and spring return.

CERTIFICATIONS

- CE marking and EAC certification.



CERTIFICATIONS

Conformity to Community Directives	2006/95/CE Low Voltage Directive
	2006/42/CE Machinery Directive
Conformity to CE Standards	EN 60204-1 Safety of machinery - Electrical equipment of machines
	EN 60947-1 Low-voltage switchgear and controlgear
	EN 60947-5-1 Low-voltage switchgear and controlgear - Control circuit devices and switching elements - Electromechanical control circuit devices
	EN 60529 Degrees of protection provided by enclosures
Markings and homologations	CE ENEC

GENERAL TECHNICAL SPECIFICATIONS

Ambient temperature	Storage -40°F/+158°F (-40°C/+70°C)
	Operational -13°F/+158°F (-25°C/+70°C)
IP protection degree	IP65 max. with dedicated cable clamp M20
Insulation category	Class II
Operation frequency	3600 operations/hour max
Cable entry	Cable clamp M20

TECHNICAL SPECIFICATIONS OF THE MICROSWITCHES

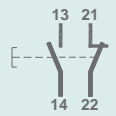
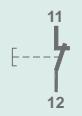
Code	PRSL0036XX	PRSL0037XX
Utilisation category	AC 15	
Rated operational current	3 A	
Rated operational voltage	250 Vac	
Rated thermal current	10 A	
Rated insulation voltage	300 Vac	
Mechanical life	1x10 ⁶ operations	
Connections	Screw-type terminal	
Wires	1x2.5 mm ² , 2x1.5 mm ² (UL - (c)UL: use 140°F (60°C) or 167°F (75°C) copper (CU) conductor and wire 16-18 AWG)	
Tightening torque	0.8 Nm	
Microswitch type	Double break, snap action	Double break, slow action
Contacts	1NO+1NC (All NC contacts are of the positive opening operation type )	1NC (All NC contacts are of the positive opening operation type )
Scheme		
Markings and homologations	CE cULus ENEC	

MAXIMUM ACTUATING DIMENSIONS

T-type rod - Cross rod with 3 maintained positions

- Pre-travel angle for rotation contact operation: 70°-49°
- Maximum rotation angle for each maintained position: 90°
- Average angle for the mechanical tripping: 48°

Rod - Rod and Roller

- Pre-travel angle for rotation contact operation: 24°
- Maximum rotation angle: 65°

Cross rod with 4 maintained positions

- Pre-travel angle for rotation contact operation: 49°
- Maximum rotation angle for each maintained position: 90°
- Average angle for the mechanical tripping: 48°
- Maintained positions each: 90°

In order to ensure proper operations, the dimensions shall not be increased; anyhow, they can be decreased, taking into account that the closer the impact point is to the center of the head, the higher the impact and the mechanical wear of rod and shaft are. IMPORTANT: the maximum impact speed is 1.35 m/s, referring to the ideal impact points showed in the drawing.

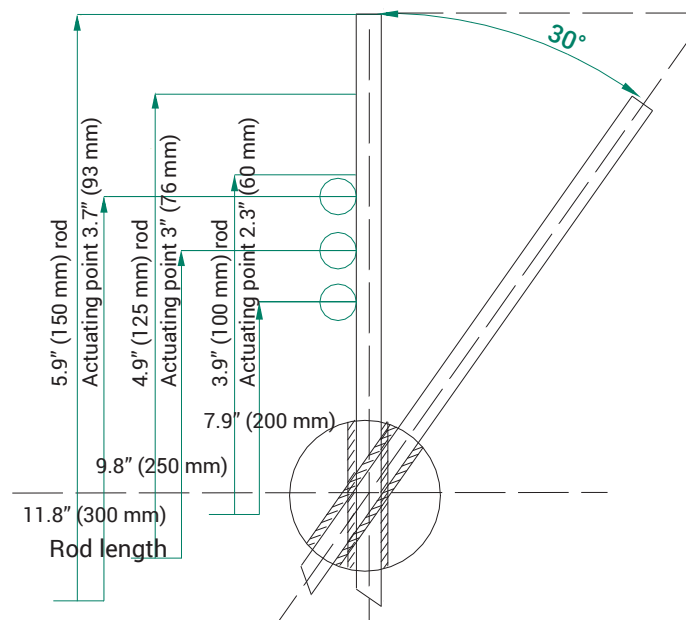

OVERALL DIMENSIONS (mm)

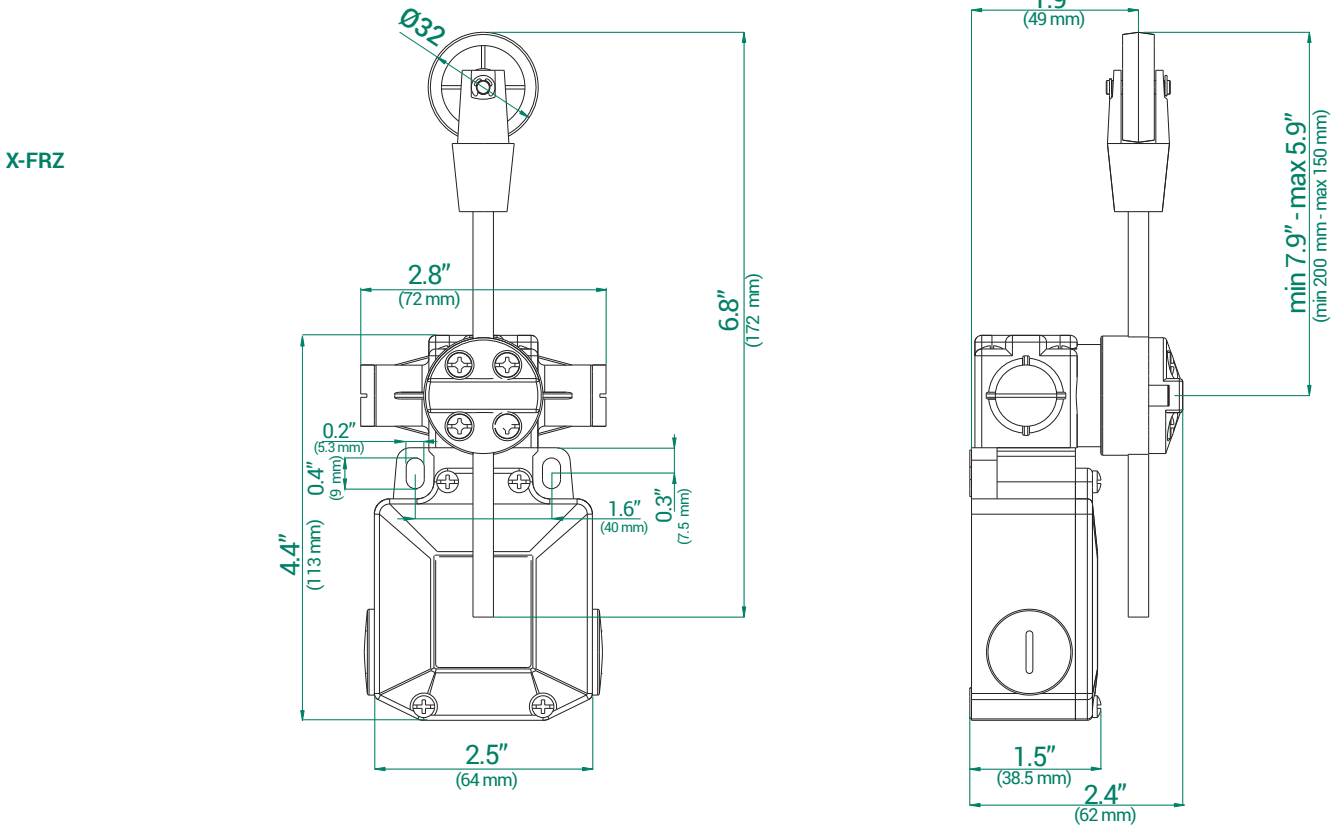
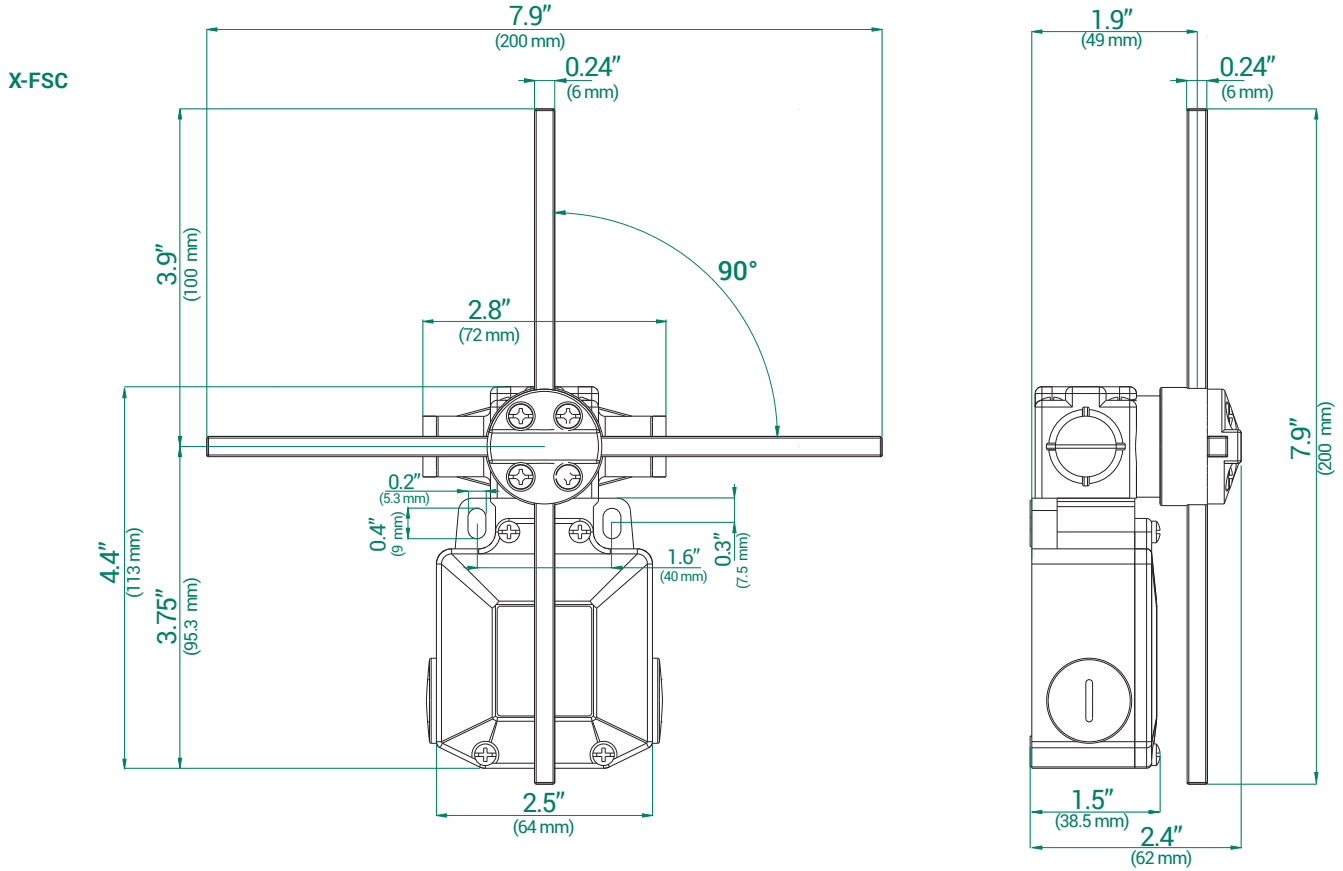



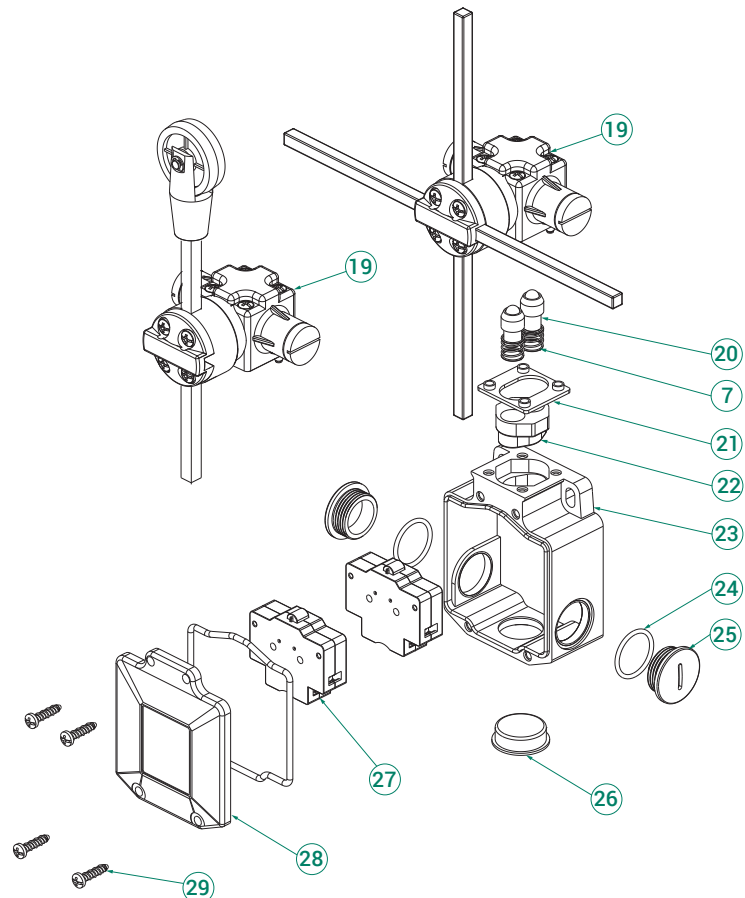
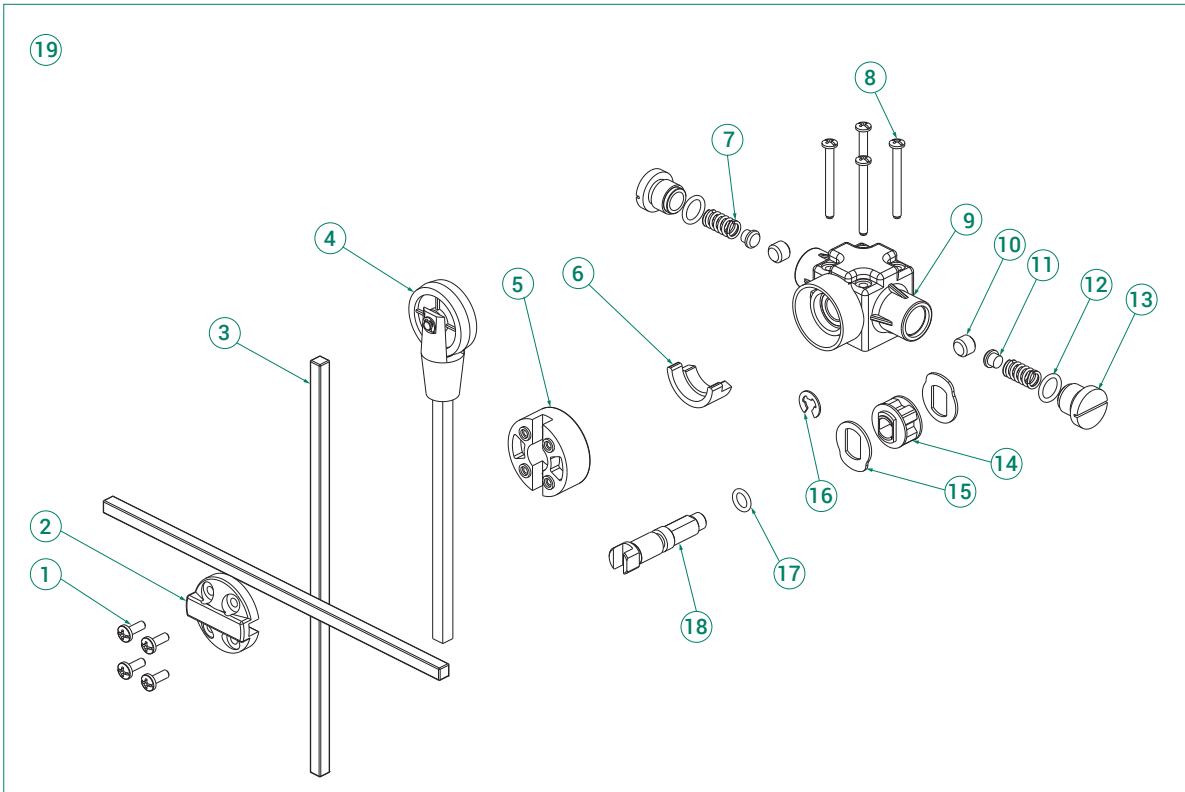



EXPLODED DRAWING

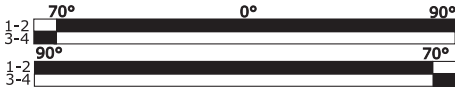
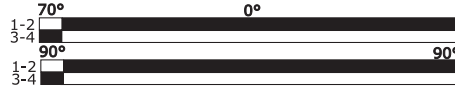
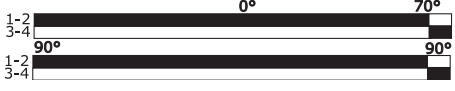

LIMIT SWITCHES X-FSC

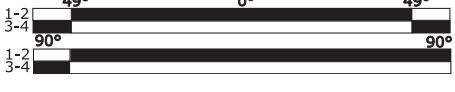
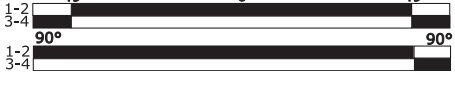
Limit switches X-FSC are equipped with 1NO+1NC snap action switches PRSL0036XX

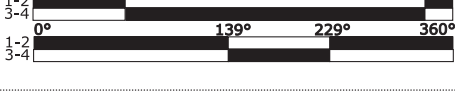



Actuating travel	Positions	Rod	Code
	3 maintained	"T" type	PF33710100
	3 maintained	Cross	PF33710200
	3 maintained	"T" type	PF33711100
	3 maintained	Cross	PF33711200
	3 maintained	"T" type	PF33712100
	3 maintained	Cross	PF33712200
	3 maintained	"T" type	PF33713100
	3 maintained	Cross	PF33713200
	3 maintained	"T" type	PF33714100
	3 maintained	Cross	PF33714200
	3 maintained	"T" type	PF33715100
	3 maintained	Cross	PF33715200
	4 maintained	Cross	PF33750100
	4 maintained	Cross	PF33751100
	4 maintained	Cross	PF33751100
	4 maintained	Cross	PF33752100
	4 maintained	Cross	PF33752100

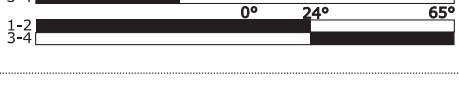
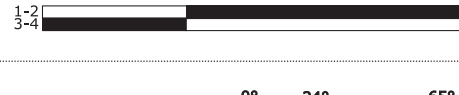
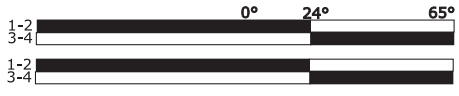
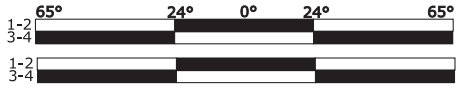
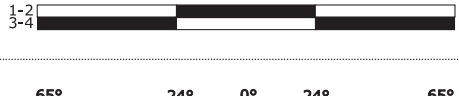
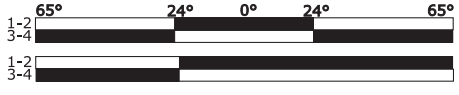
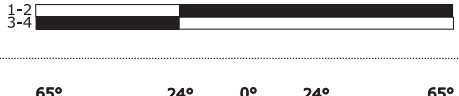
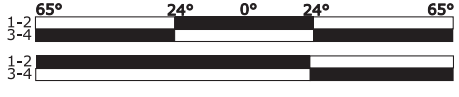

LIMIT SWITCHES X-FRZ

Limit switches X-FRZ are equipped with 1NO+1NC snap action switches PRSL0036XX 

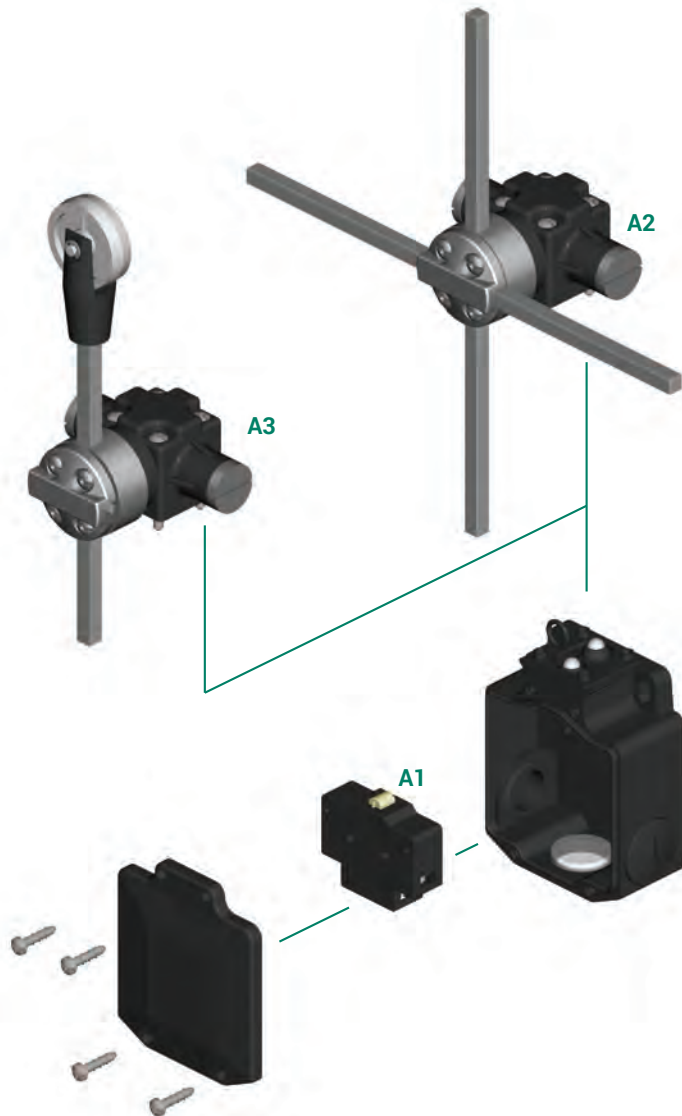
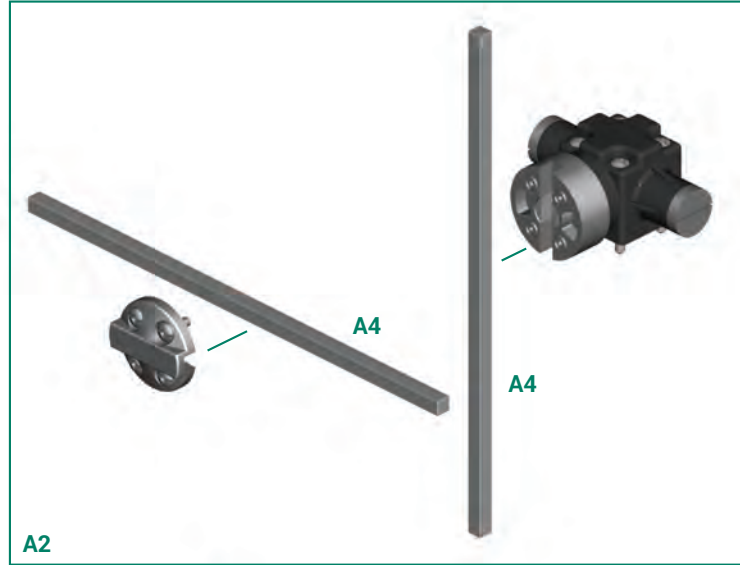
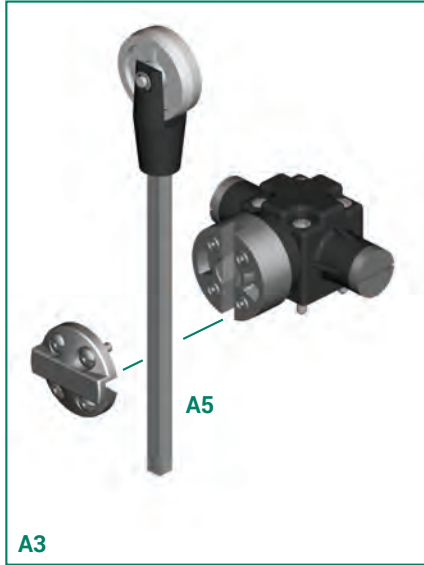

Actuating travel	Positions	Rod	Code
	Spring return	Rod	PF33700100
	Spring return	Rod and roller	PF33700200
	Spring return	Rod	PF33701100
	Spring return	Rod and roller	PF33701200
	Spring return	Rod	PF33702100
	Spring return	Rod and roller	PF33702200
	Spring return	Rod	PF33703100
	Spring return	Rod and roller	PF33703200
	Spring return	Rod	PF33704100
	Spring return	Rod and roller	PF33704200
	Spring return	Rod	PF33705100
	Spring return	Rod and roller	PF33705200

ASSEMBLY DRAWING





COMPONENTS

Switches

Ref.	Drawing	Description	Scheme	Code
A1		1NO+1NC snap action switch		PRSL0036XX
		1NC slow action switch		PRSL0037XX

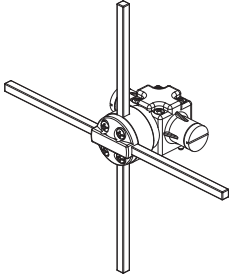
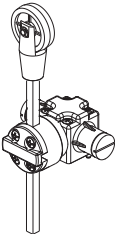
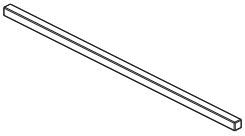
Accessories

Ref.	Drawing	Description	Code
A2		Head with cross rods	PF33____TE Codes on request
A3		Head with rod and roller	PF33____TE Codes on request
A4		Rod 6x6x200 mm	PRT03007PE
A5		Rod 6x6x130 mm with roller	PRSL0850PI

USE AND MAINTENANCE INSTRUCTIONS

The limit switches X-SFC and X-FRZ are electromechanical devices for low voltage control circuits (EN 60947-1, EN 60947-5-1) for use as electric equipment on machines (EN 60204-1) in compliance with the essential requisites of the Low Voltage Directive 2006/95/CE and the Machine Directive 2006/42/CE.

The limit switch is designed for use in industrial environments with even very severe climatic conditions (working temperatures from -25°C to +70°C and is suitable for use in tropical environments). The equipment is not suitable for use in environments with a potentially explosive atmosphere, in the presence of corrosive agents or high percentage of sodium chloride (saline mist). Contact with oil, acids and solvents may damage the equipment; avoid using them for cleaning. The limit switches is not suitable for use in environments with a potentially explosive atmosphere.

Operations for installation and correct wiring of limit switch

- Important: for correct operations, install the device far from sources of heat that could raise its temperature higher than 70°C.
- Position the limit switch so that the machine or one arm of it strikes the rod (3)* in the positions indicated in the maximum drive measurements; make sure the wires are not taut, twisted and/or force into excessive curvatures.
- Mark the fastening holes on the supporting wall and drill the holes.
- After fastening, make sure the rod is perfectly vertical, that the rods (3) are securely fastened in the head and that the points of impact are as verified previously.
- Proceed with electric wiring taking care to tighten the terminals on the switches (27), after manually checking the on/off function.
- Tighten the terminal screws with a torque of 0.8 Nm; insertability of wires into the terminals 1x2.5 mm² - 2x1.5mm² (UL - (c)UL: use 60 or 75°C conductor and wire size No. 16-18 AWG, stranded or solid).
- Close the lid (28) taking care to position the gasket in its housing.
- Tighten the wire clamp taking care to see that the rubber inside adheres to the sheathing on the wire.

- The installation will be complete after checking once or twice that the machine is properly slowed and/or stopped by the limit switch installed.

Operations of routine maintenance

- Make sure the limit switch is securely fastened in place and the fasteners are tightened properly.
- Make sure there are no infiltrations of water through the wire clamp(s) and that the rubber sleeve is intact and flexible. Open the lid (28) and check that the gasket is intact and flat in its housing.
- Check that the switches (27) are properly wired and the terminals securely fastened; test the on/off mechanism by hand.
- Make sure the head turns without forcing, that it is clean and moves without uncertainty between one position and the next.
- Make sure the screws (1) on the head are properly tightened. If there is any difficulty in switching and positioning the head, replace the limit switch.
- Check the conditions of the rods (3) and make sure they are positioned correctly: if the rods are not perfectly straight they should be replaced and repositioned carefully in accordance with the specifications.

NOTE: FOLLOW THE INSTRUCTIONS CAREFULLY WITH REGARD TO THE SPEED AND POSITION OF THE RODS INDICATED IN THE MAXIMUM DRIVE MEASUREMENTS. FAILURE TO FOLLOW THE SPECIFICATIONS INDICATED MAY JEOPARDIZE THE FUNCTION AND SAFETY OF THE SYSTEM.

Any change to parts of the limit switch will invalidate the rating plate data and identification of the device, and render the warranty null and void. In case of replacement of any part, use only original replacements.

Springer Controls Company and TER are not liable for damages caused by improper use of the device and installation which is not made correctly.

* Please refer to the exploded drawing in the catalog.