

10A Slip Ring Collector



Slip ring collector, consisting of rings coupled with brushes, designed for small jib cranes. Compact sized and equipped with 4 rings.

FEATURES

- Suitable for transmitting current with 50/60 Hz supply frequency.
- Extreme temperature resistance: -13°F to +158°F (-25°C to +70°C).

OPTIONS

- Version with driving slots available.
- Available with coupling flange.

CERTIFICATIONS

- CE marking and EAC certification.



CERTIFICATIONS

Conformity to Community Directives	2014/35/UE Low Voltage Directive
	2006/42/CE Machinery Directive
Conformity to CE Standards	EN 60204-1 Safety of machinery - Electrical equipment of machines
	EN 60309-1 Plugs, socket-outlets and couplers for industrial purposes - General requirements
	EN 60529 Degrees of protection provided by enclosures
Markings and homologations	CE EAC

GENERAL TECHNICAL SPECIFICATIONS

Ambient temperature	Storage -40°F/+158°F (-40°C/+70°C)
	Operational -13°F/+158°F (-25°C/+70°C)
IP protection degree	IP 00
Insulation category	Class I
Operating positions	Any position

ELECTRICAL SPECIFICATIONS

Rated operational current	10 A
Rated operational voltage	400 Vac
Rated insulation voltage	660 Vac
Max. speed	3 rev./min
Connections	Faston 6.3 mm

OVERALL DIMENSIONS

With driving slot

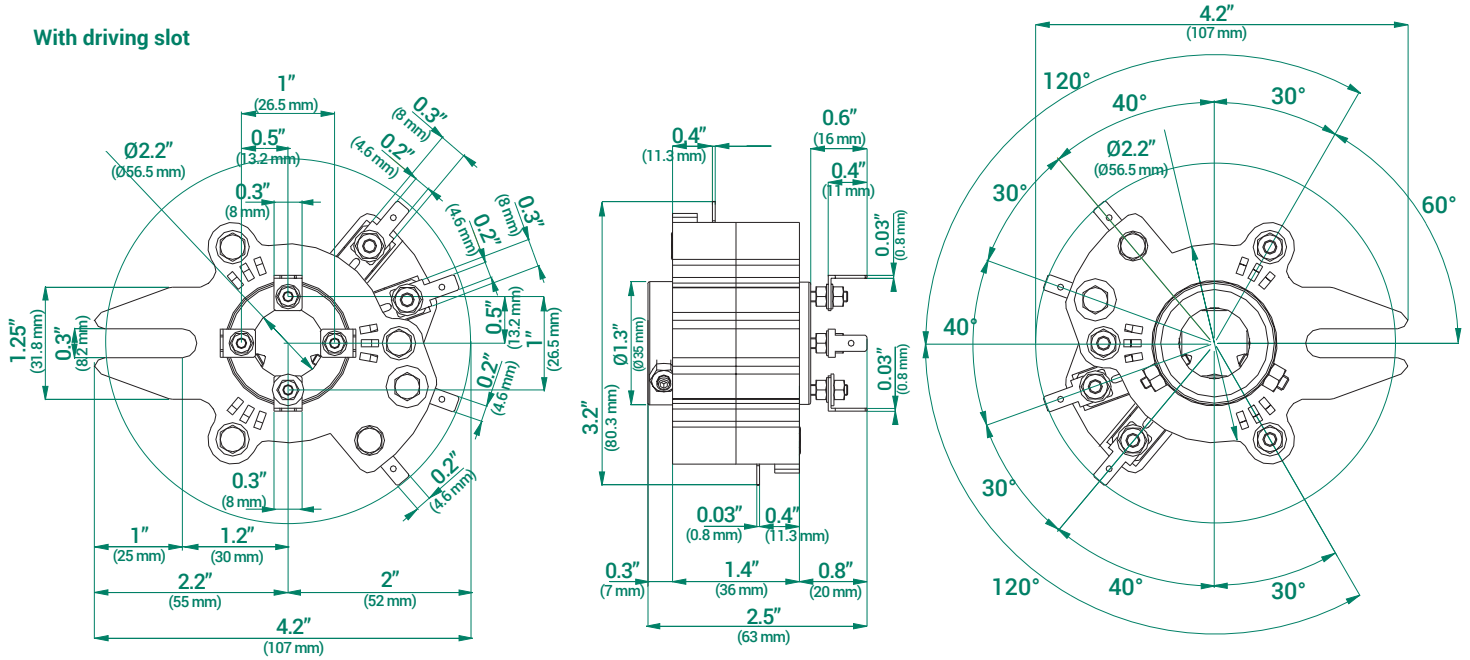

Without driving slot

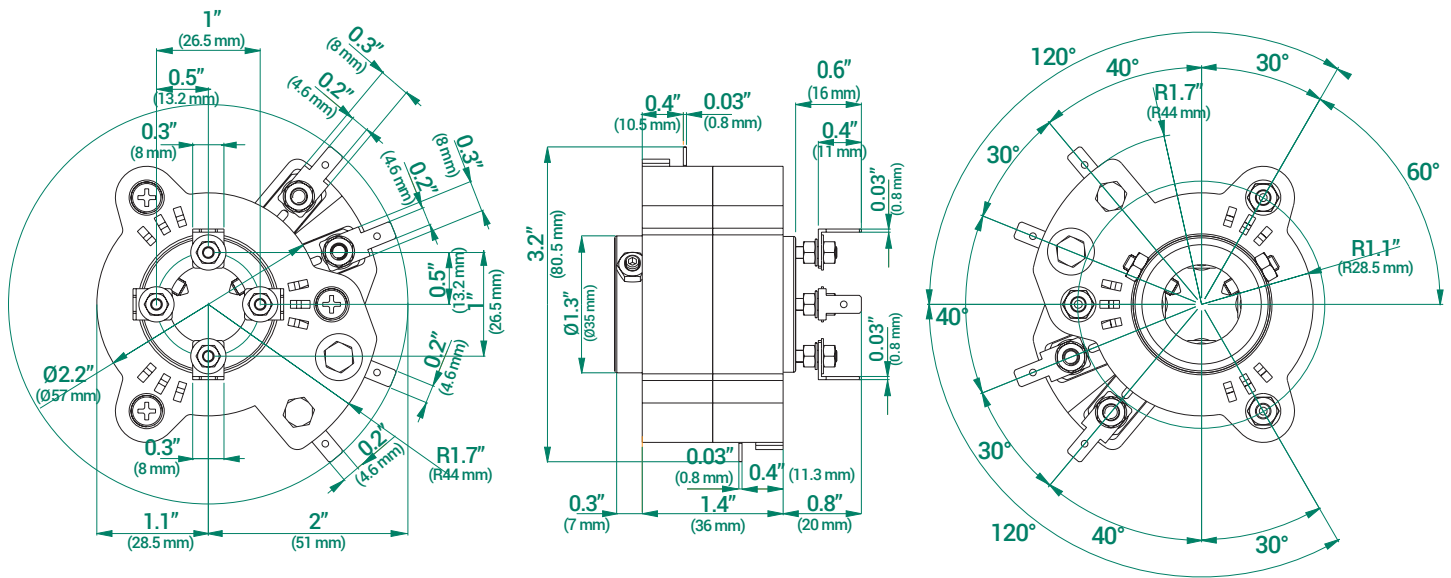

SLIP RING COLLECTORS

Description	Code
Slip ring collector with driving slot	PF21270100
Slip ring collector without driving slot	PF21270200
Slip ring collector with Ø 40x30 mm flange	PF21270101

USE AND MAINTENANCE INSTRUCTIONS

The slip ring collector 10A is an electromechanical device for low voltage control circuits (EN 60947-1, EN 60947-5-1) for use as electric equipment on machines (EN 60204-1) in compliance with the essential requisites of the Low Voltage Directive 2014/35/UE and the Machine Directive 2006/42/CE.

The collector is designed for use in industrial environments with even very severe climatic conditions (working temperatures from -13°F to +158°F (-25°C to +70°C) and is suitable for use in tropical environments). The equipment is not suitable for use in environments with a potentially explosive atmosphere, in the presence of corrosive agents or high percentage of sodium chloride (saline mist). Contact with oil, acids and solvents may damage the equipment; avoid using them for cleaning.

The installation and maintenance of the slip ring collector shall be carried out by qualified and trained personnel. Wiring shall be properly done according to the current instructions.

We recommend cleaning the device during routine maintenance to remove the residues of metallic dust that may deposit on the rings.

After about 250 working hours clean the rings and contacts.

Installation

Fasten the stator (or fixed part) using the C iron found on the piece; make sure it is securely in place and cannot be moved by vibrations and/or impact.

Fasten the rotor (or mobile part) on a cylindrical structure (max diameter 19.5mm) using the two dowels and a 2 mm hexagonal wrench to tighten the counternuts.

Proceed to wire the fastons for the three phases and ground wire referring to the letters on the fixed and mobile part. We recommend using fastons with insulated body.

Make sure that during rotation the fastons do not interfere with passive and/or active parts of the machine and that the wires do not become entangled.

WARNING: the protection degree of the product is IP00 so it has to be positioned properly, using barriers/obstacles to avoid accidental contact with active parts. Always disconnect from power supply before operating near the collector.

Maintenance

The collector does not require any operations of maintenance, lubrication and/or greasing.

At least once a year check the mechanical fastenings of the fixed part and make sure the rotor is securely fastened and the electric wires are in good condition.

Make sure that during rotation the fastons do not interfere with passive and/or active parts of the machine and that the wires do not become entangled.

Keep the product free of dust and dirt and make sure the plastic parts are in perfect conditions: in case of any breakage and/or deterioration replace the product.

Any change to parts of the collector will invalidate the rating plate data and identification of the device, and render the warranty null and void. In case of replacement of any part, use only original replacements.

Springer Control Company and TER are not liable for damages caused by improper use of the device and installation which is not made correctly.